

Grandview



Large  
Stage

巨型木箱工程幕



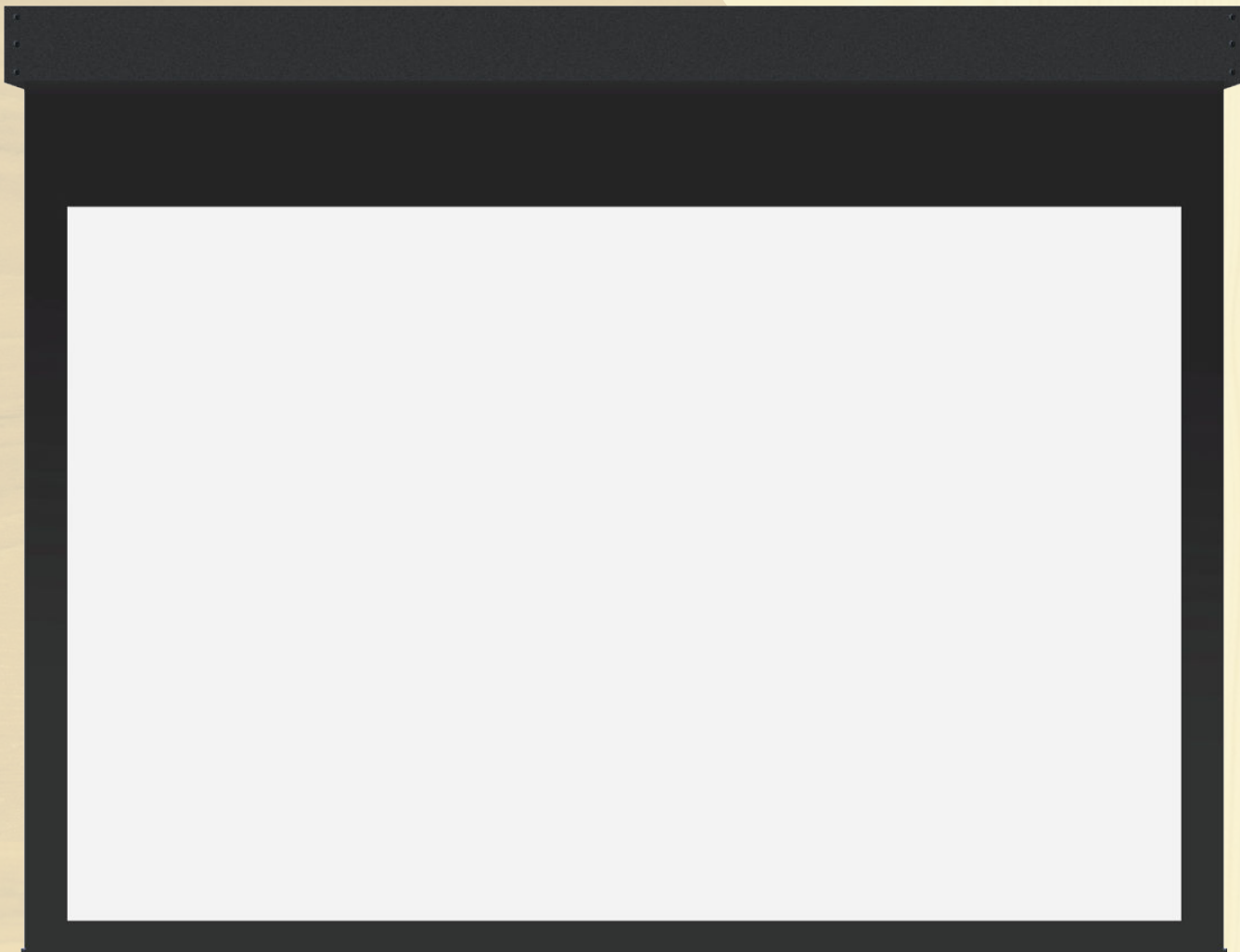

- 金屬支架配合高強度雙層粘合木製外箱,採用貫穿螺絲緊固,令產品懸掛安裝更安全。

- 250mm大口徑高強度轉管。

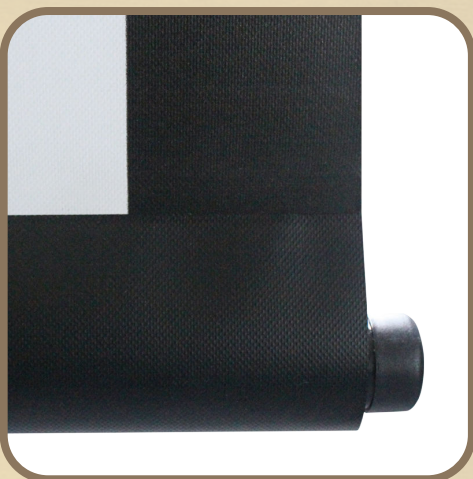

- 馬達會速更換模式

側蓋設計為維修活口,無需拆卸外殼,不必拆卸幕布及轉管,即可更換馬達。

- 幕布調節桿

可有效避免幕布出現“V”型波紋。

# 安裝方式

懸吊式

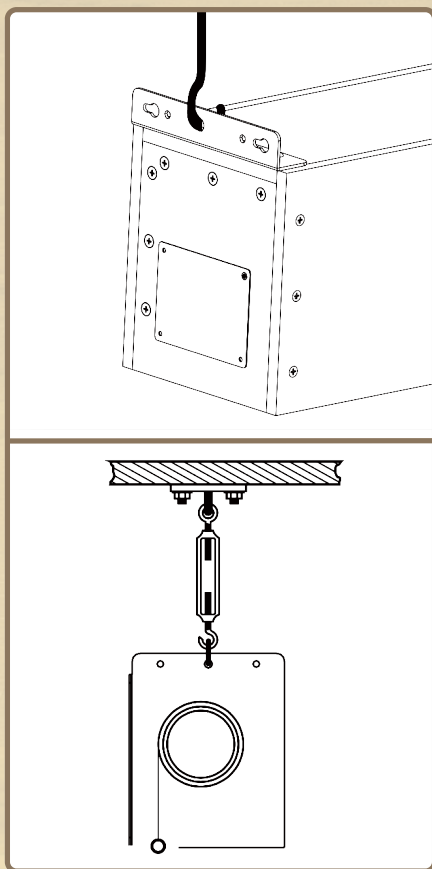

頂裝式

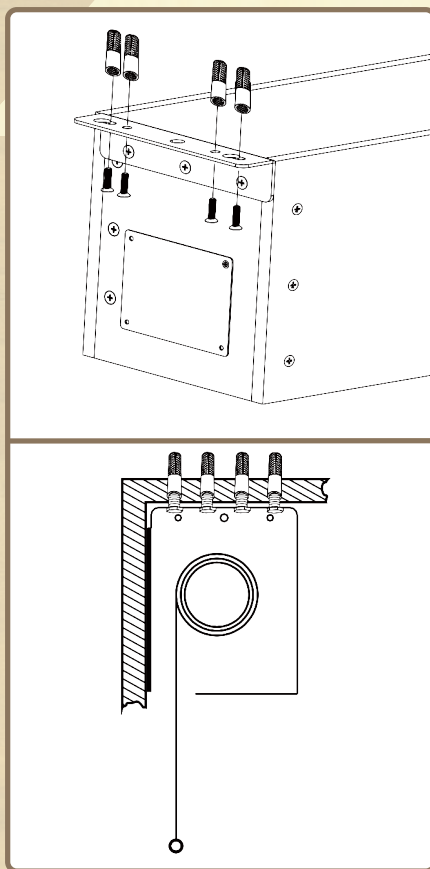

懸吊式螺桿連接

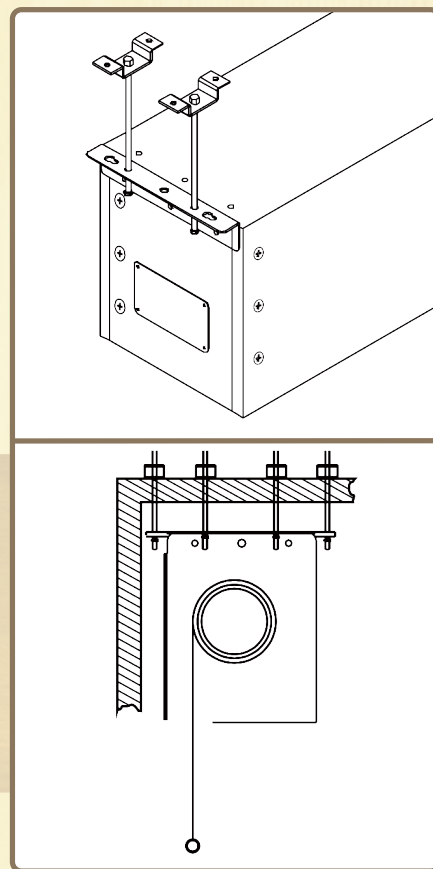

# 幕布特性



WM9是四層複合結構德國進口工程幕,表面塗布專業級的顯像塗層,其基層為特殊纖維,幕布的經線和緯線一致。

實測色彩還原達到97%,幕布的厚度0.7mm,能做到裁切後無卷邊、不變型。

無論橫方向和豎方向使用都沒有任何影響。

並且最大尺寸能做到400"(16:9)無拼接。

WM9  
蔗白幕布



視角



亮度增益



防火



環保



防霉



防潮



可擦洗



尺寸比例	投影幕對角線	型號	投影畫面寬W*高H	總高A	上黑邊B3	上/左/右黑邊B1/B2	外殼總寬L
4:3	450"	LS-M450	9145 × 6860	8035	600	80	9573
	500"	LS-M500	10000 × 7500	8675			10428
16:9	400"	LS-M400W	8855 × 4981	6156			9283
	450"	LS-M450W	10000 × 5625	6800			10428
	500"	LS-M500W	11070 × 6226	7401			11498
16:10	400"	LS-M400WN	8616 × 5385	6560			9044
	450"	LS-M450WN	9693 × 6058	7233			10121
	500"	LS-M500WN	10770 × 6731	7906			11198

單位:mm

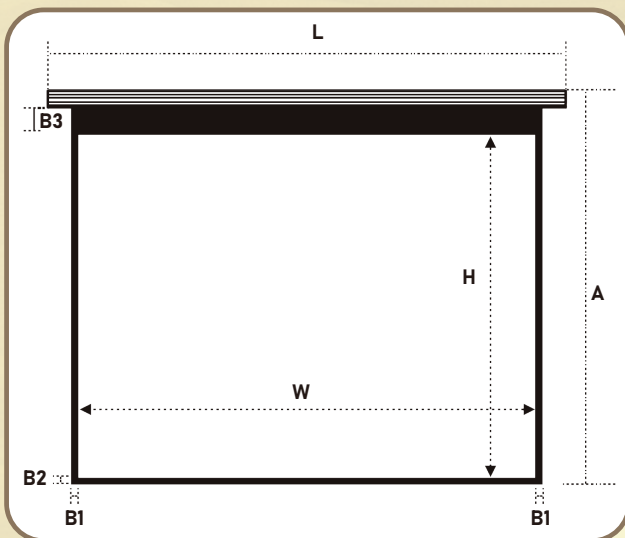

正視圖

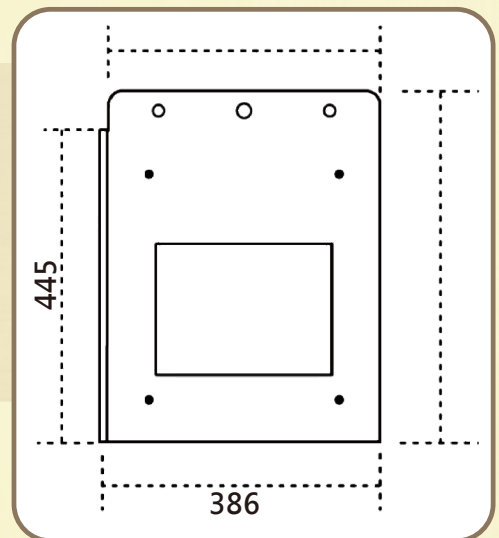

側視圖

